

# Process data reconciliation in nuclear power plants

M. Langenstein  
J. Jansky

BTB-Jansky GmbH  
71229 Leonberg  
Gerlingerstrasse 151  
Germany  
Internet: [www.btbjansky.com](http://www.btbjansky.com)  
e-mail: [btb@btbjansky.com](mailto:btb@btbjansky.com)

## Abstract

Process data reconciliation with VALI III is a method for monitoring and optimising industrial processes as well as for component diagnosis and condition-based maintenance in measurement technology.

Employing process data reconciliation in nuclear power plants enables thermal reactor power to be determined with an uncertainty of less than  $\pm 0.5\%$ , without having to install additional precision instrumentation to measure the feed-water mass flow. This is equivalent to a measurement uncertainty recapture power uprate potential of about 1.5 %.

In addition, process data reconciliation permits any drift in the measured values to be detected at an early stage, yet still allows the reconciled variables (such as thermal reactor power) to be calculated with **consistently high precision**. Without reconciliation drifting of measured values for the feed water temperature or the feed-water mass flow could remain undetected, the thermal reactor power calculation may incorporate an unacceptably large deviation, negatively impacting both safety and economy.

## Introduction

All measurements are erroneous. The problem is, that with incorrect measurements the conservation laws cannot be fulfilled. The solution for this problem is the process data reconciliation with VALI III [1]. Process data reconciliation with VALI III is a mathematical-statistical method. When a plant model is created for an industrial process, **all available or redundant measured variables** must first be assigned to the model streams and units together with their respective measurement uncertainties.

The **overdetermined system of equations** that results when all available redundancies and secondary conditions (conservation laws) are taken into account is resolved with the aid of the Gaussian correction principle. Contradictory measured values are converted to unequivocal, "true" values for the measured variables, to obtain closed mass, energy and materials balances. The corrected covariance matrix is used to determine the corrected confidence intervals of the results.

This method, described in VDI 2048 [2], is:

- The best possible quality control mechanism for identifying serious measurement errors, and
- A precondition of process monitoring, process optimisation and maintenance optimisation [3], [4], [5], [6].

Process data reconciliation is used in nuclear power plants, combined-cycle gas turbine power plants, coal-fired power plants, incineration plants, gas distribution systems and the chemical and petrochemical industries. This paper describes the theoretical basis of process data reconciliation with VALI III according to VDI 2048 as well as practical experience with online process data reconciliation in nuclear power plants (boiling water and pressurised water reactors).

## Theoretical basis [2]

### *Gaussian correction principle*

Corrections  $v$  are made to the measured values  $x$  according to equation (1), in order to obtain estimated values (reconciled values)  $\bar{x}$ .

$$\bar{x} = x + v \quad (1)$$

The corrections  $v$  must be determined such that the quadratic form

$$\xi_0 = v \cdot S_X^{-1} \cdot v \Rightarrow \min \quad (2)$$

$S_X^{-1}$  inverse empirical covariance matrix of random variables  $X$   
 $\xi_0$  square form of errors

becomes a minimum. The empirical covariance matrix  $S_X$  is the estimated value for the uncertainty of the measured variables  $X$ . This general formulation also includes the existence of covariances, in other words the interdependencies of the measuring points. Equation (2) represents the general form of the Gaussian correction principle.

### *Quality control and detecting suspected tags (serious errors)*

If the condition

$$\left| \frac{v_i}{\sqrt{s_{v,ii}}} \right| \leq 1.96 \quad (3)$$

is not satisfied, the measuring point or the estimated value of the associated variance will incorporate a serious error. This measured or estimated value should consequently be

challenged. In this condition the corrected measured value  $v_i$  refers to the covariance matrix of the corrections.

### **Correlation coefficients for assessing delta measurements**

The method described in VDI 2048 for assessing delta measurements takes account of the interdependency of values measured at different times but with the same chains. Correlation coefficients have to be defined between the values measured at different times, to allow random errors in these measuring chains to be considered. VALI III supports this.

### **Description of the method based on a simple example**

The functional principle of process data reconciliation is described here with the aid of a simple example. **Figure 1** shows a splitter. The entering stream is split into two partial streams. It is assumed that measured values which must satisfy the mass balance

$$\overset{\bullet}{m}_{\text{stream 1}} = \overset{\bullet}{m}_{\text{stream 2}} + \overset{\bullet}{m}_{\text{stream 3}} \quad (4)$$

are available for the mass flows of all three streams (STREAM 1: 500 t/h, STREAM 2: 245 t/h and STREAM 3: 250 t/h). It can be seen that a simply overdetermined system exists, and that the mass balance cannot be closed with these values (refer to equation (5)).

$$500 \text{ t/h} \neq 245 \text{ t/h} + 250 \text{ t/h} \quad (5)$$

If, on the other hand, a standard deviation is assigned to each measured value (in this case  $\pm 5\%$ , refer to Figure 1) and the correction calculation is performed, the "true" (reconciled) values are calculated taking account of the minimisation criterion in equation (2). In this example (without correlations), the minimisation criterion of equation (2) takes the following form:

$$OBJECTIVE\ FUNCTION = \sum \left( \frac{\text{measured value} - \text{reconciled value}}{\text{standard deviation}} \right)^2 = \text{minimum} \quad (6)$$

The reconciled "true" values of the three mass streams are documented in **Figure 1**. They satisfy the mass balance equation (4); refer to equation (7)

$$496.64 \pm 14.35 \text{ t/h} = 245.81 \pm 11.2 \text{ t/h} + 250.84 \pm 11.4 \text{ t/h} \quad (7)$$

The results report of the reconciliation run is shown in **Figure 2**. In **Figure 3 and 4** the hand calculation is documented. The OBJECTIVE FUNCTION is calculated as 0.1 under the conditions specified for this example. There is no indication of any serious errors. The CHI SQUARE test, namely  $CHI\ SQUARE > OBJECTIVE\ FUNCTION$ , is passed (3.8 is greater than 0.1); refer to Figure 2. The calculated true values therefore do not need to be challenged.

If an error is deliberately incorporated, i.e. if it is assumed, for instance, that the mass flow measurement for stream 1 yields 550 t/h, the following result is returned by the reconciliation system:

$$520.86 \pm 15 \text{ t/h} = 252.77 \pm 11.3 \text{ t/h} + 259.09 \pm 12.1 \text{ t/h} \quad (8)$$

The OBJECTIVE FUNCTION is calculated as 10.9 under the conditions specified for this example. The CHI SQUARE test, namely  $\text{CHI SQUARE} > \text{OBJECTIVE FUNCTION}$ , is not passed (3.8 is less than 10.9); refer to **Figure 5**. The values marked with an "\*" in Figure 5 must therefore be challenged (in this case all three measured values).

It is thus clear that the VALI III system for process data reconciliation not only closes the mass balance but also provides an indication of serious errors.

This is a very simple example. The data reconciliation will be improved, if more redundancies and a more complex model (more connections between the streams) exists.

### ***Consideration of energy and materials balances***

The IAPWS-IF 97 steam table, among others, is supplied with VALI III to permit thermodynamic system variables to be calculated for the water/steam process. VALI III also allows any chemical reaction equations (important, for example, when considering materials balances in combustion processes) to be mapped and integrated in the model. The functionality of VALI III is described in detail in the manual [1].

### **Use in nuclear power plants**

Process data reconciliation with VALI III [1] is used in nuclear power plants in order to:

- Perform acceptance tests, also for delta measurements (retrofitting, taking account of correlation coefficients)
- Evaluate maintenance activities like cleaning the compressor or condenser (delta measurements, taking account of correlation coefficients)
- Trace start-up activities in the plants
- Determine the mean coolant temperature more accurately
- Determine the thermal reactor power more accurately
- Use the reconciliation results as a calibration standard
- Reduce the cost of calibrating measuring points
- Evaluate exact performance indicators

### ***Process data reconciliation in a 4-LOOP PWR (1350 MW)***

**Figure 6** documents the primary circuit of a nuclear power plant on the VALI III user interface. The VALI III model of this NPP has 123 redundancies; 270 measurements are implemented.

The coolant temperature (KMT) is one of the most important controlled variables in the nuclear power plant process. It is therefore essential to determine this temperature as accurately as possible. **Figure 7** is a graph showing the measured and reconciled mean coolant temperatures during a start-up process. It reveals that the measured temperatures are approximately 1 K higher than the reconciled temperatures, and that at the end of the start-up process the reconciled coolant temperature is close to the maximum permissible temperature, namely 308.5 °C. If the measured coolant temperature were to be used as a basis for control without any indication of the true temperature being provided by the reconciled data, the plant would be unable to run at full power.

**Figure 8** compares the feed-water mass flow measurement of one steam generator with the reconciled values. The deviation between the measured feed-water mass flow and the reconciled mass flow is up to 13 kg/s, equivalent to 2 % of the total mass flow (accuracy range of the measuring devices). The direct influence of the differences between the measured and reconciled feed-water mass flows is described in **Figure 9**. The reconciled thermal reactor power is up to 30 MW<sub>th</sub> lower than the thermal reactor power based on measured data (main influence of the feed-water mass flow measurement). The aim is to use the reconciled values as a calibration standard and to calibrate the feed-water mass flow measurements such that the measured values correspond to the reconciled values. In this plant, the electrical output can be increased by 13 MW<sub>el</sub>.

**Figure 10** confirms how the feed water pressure measurement drifts upstream of one steam generator. The same graph also shows the PENALTY function over the drift period. The PENALTY function is the sum of all deviations of the model as a whole according to equation 6. During operation under 100 % load, the PENALTY value for this nuclear power plant is 70. The measuring point drift causes the PENALTY value to rise to 300. This rise in the PENALTY value is caused by the increasingly large deviation between the measured value and the reconciled value (refer to equation (6)). Changes to the PENALTY value therefore provide a quick and reliable indication of process changes or drifting measuring points without impairing the accuracy of the reconciled results.

Measured values with a crucial influence on the magnitude of the PENALTY value are marked as suspected tags by the process data reconciliation system and stored in a separate file. Only those measured values which do not satisfy equation (2) are marked and stored.

**Figure 11** shows a typical report. The report subsequently serves as a basis for the performance of condition-based maintenance on these measuring chains.

### ***Process data reconciliation in a 3-LOOP PWR (920 MW)***

The VALI III model of this NPP has 96 redundancies; 219 measurements are implemented (temperatures: 95, mass flows: 42, pressures: 49, others: 33). **Figure 12** shows the measured (blue) and reconciled values (red) together with the performance indicators for a reconciliation run on one flow sheet.

**Figure 13** is a graph showing four measured values for a mass-flow measuring orifice as well as the associated reconciled value. The reconciled value is approximately 7 kg/s less than the

mean of the four measured values. If all three LOOPS are taken into account, the total measured feed-water mass flow is approximately 19 kg/s higher than the reconciled mass flow (equivalent to a deviation of 1.4 % if the total measured feed-water mass flow is 1330 kg/s).

The influence of this deviation on the thermal reactor power is shown in **Figure 14**. The reconciled thermal reactor power (approx. 2440 MW<sub>th</sub>) is around 30 MW<sub>th</sub> less than the thermal reactor power calculated on the basis of measured values (approx. 2470 MW<sub>th</sub>).

### ***Measurement uncertainty recapture power uprate***

The thermal reactor power could be uprated by reducing the result uncertainties of the measured feedwater mass flow values, which are crucial for the thermal reactor power calculation. By reducing the result uncertainty to less than  $\pm 0.5$  % with the help of a process data reconciliation system, a measurement uncertainty recapture power uprate potential of 1.5 % could be utilised. **Figure 15** shows a potential of 1.5 % (50 MW<sub>th</sub>) for a BWR plant in which process data reconciliation with VALI III has been installed for the past ten years. Compared to other methods of reducing the measurement uncertainty for thermal reactor power, such as installing more precise individual measuring instruments, the reconciled thermal reactor power principle combines consistently high accuracy with consideration of drifting measured values, for example of the feed water temperature or mass flow.

### ***Assessment of retrofit and maintenance activities***

In order to permit assessments of delta measurements (before and after an activity) of the kind necessary in connection with retrofit or maintenance activities, process data reconciliation must also take account of correlation coefficients. The differences between the results with or without correlation coefficients are described taking the example of compressor cleaning work on a gas turbine. **Figure 16** presents the results on a graph. A power increase of  $4.02 \pm 1.77$  MW is obtained if correlation coefficients are taken into consideration. If these correlation coefficients are neglected, the power increase is calculated to be only  $3.92 \pm 3.17$  MW (result uncertainties corresponding to the 95 % confidence interval).

If the power increase corresponding to 95 % probability is calculated, the figure is

- 2.54 MW with correlation coefficients, or
- 1.16 MW without correlation coefficients.

Compared to other methods (which do not take account of correlation coefficients), this method of assessing delta measurements with correlation coefficients therefore yields considerably more detailed information about the true power increase. As a result, the optimum time from a commercial point of view to repeat maintenance activities can be determined more accurately.

Furthermore, the method described here for assessing delta measurements enables:

- Power increases caused by RETROFIT activities to be determined more precisely, and
- A gradual deterioration of the plant as a whole, and hence of its efficiency, to be detected at an early stage on the basis of a reference condition (good condition of the plant).

## Conclusions

The process data reconciliation method with VALI III describes industrial processes extremely accurately. The results can be used in nuclear power plants both for measurement uncertainty recapture power uprating and for condition-based maintenance. The potential financial benefits far exceed the necessary investment costs [7].

## References

- [1] VALI III USER GUIDE, BELSIM S.A., Liege, Belgium, October 2001
- [2] VDI 2048, "Uncertainties of measurement during acceptance tests on energy-conversion and power plants - fundamentals", October 2000
- [3] U. Brockmeier; "Validierung von Prozeßdaten in Kraftwerken" VGB-Kraftwerkstechnik Issue 9/99 Pages 61-66
- [4] E. Grauf, J. Jansky, M. Langenstein; Investigation of the real process data on basis of closed mass and energy balances in nuclear power plants (NPP); SERA-Vol. 9, Safety Engineering and Risk Analysis - 1999, Pages 23-40; edited by J.L. Boccio; ASME 1999
- [5] Grauf, E., Jansky, J., Langenstein, M.: Reconciliation of process data in nuclear power plants (NPPs), 8th International Conference on Nuclear Engineering (ICONE) April 2-8, 2000 Baltimore, MD USA
- [6] M. Langenstein, J. Jansky: Process data validation in CCGT and nuclear power plants, Paper # O03/2, SmiRT 16, Washington DC, August 2001
- [7] H. Eitschberger, M. Neuhauser: 10 Years Experience with Process Data Reconciliation at KKL, EPRI Nuclear Power Performance Improvement Seminar, July 15-16, 2002; Saratoga Springs

## Figures

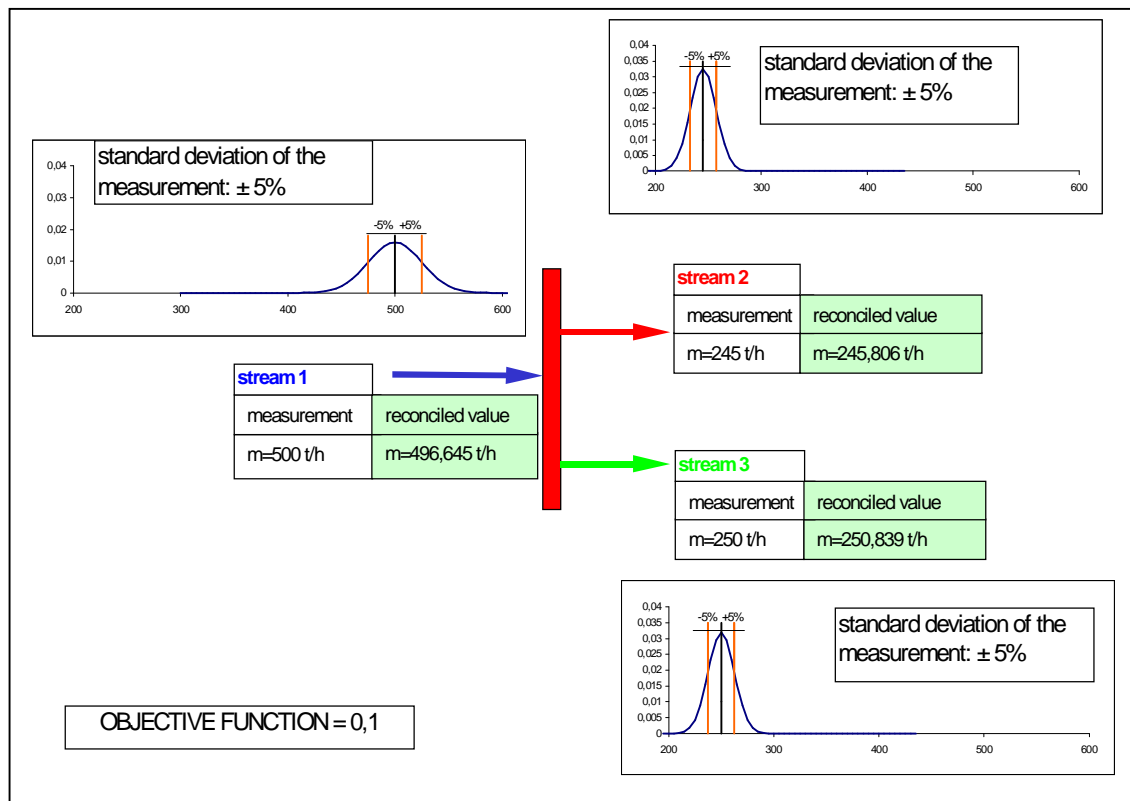


Figure 1: Example

```

NUMBER OF EQUATIONS :           4
NUMBER OF UNMEASURED VARIABLES : 3
NUMBER OF MEASURED VARIABLES :   3
NUMBER OF VARIABLES CONSIDERED CONSTANT : 0
OBVIOUS NUMBER OF REDUNDANCIES : 1
TOTAL NUMBER OF REDUNDANCIES :   1
NUMBER OF TRIVIAL REDUNDANCIES : 0
  
```

Convergence achieved

```

OBJECTIVE FUNCTION           = 0.103123
CHI-SQUARE                   = 3.84000
SUM OF SQUARE RESIDUES      = 0.201948E-27
NUMBER OF BOUNDS ACTIVATED BY SOLVER = 0
NUMBER OF VARIABLES CLOSE TO BOUNDS = 0
NUMBER OF ELIMINATED TAGS   = 0
NUMBER OF FLAGGED TAGS      = 0
  
```

PENAL. : Penalty according to VDI-2048 =  
 ( Correction / SQRT( Max ( Variance(correction) , Variance(measure) / 10. ) ) \*\* 2

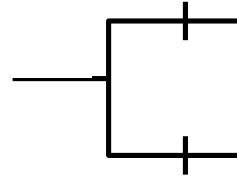
TAG NAME	MEA.VAL.	MEA.ACC.	REC.VAL.	REC.ACC.	PENALTY	P.U.
STREAM1_M	500.00	5.00 %	496.64	2.89 %	0.10	t/h
STREAM2_M	245.00	5.00 %	245.81	4.56 %	0.10	t/h
STREAM3_M	250.00	5.00 %	250.84	4.55 %	0.10	t/h

new corrected confidenz interval

Figure 2: result-report

Measurement values with specified standard deviations

$$m = \begin{bmatrix} m_1 = 500 \pm v_{x1} \text{ where } v_{x1} = 25 \text{ t/h} \\ m_2 = 245 \pm v_{x2} \text{ where } v_{x2} = 12,25 \text{ t/h} \\ m_3 = 250 \pm v_{x3} \text{ where } v_{x3} = 12,5 \text{ t/h} \end{bmatrix}$$



$$s_{xi}^2 = \left( \frac{v_{xi}}{t} \right)^2 \text{ with } t = 1,96 \text{ implying a 95\% confidence interval (1)}$$

Covariance matrix

$$S_x = \begin{bmatrix} s_{x1}^2 & s_{x1i} & s_{x1k} & s_{x1n} \\ s_{xi1} & s_{xi}^2 & s_{xik} & s_{xin} \\ s_{xk1} & s_{xki} & s_{xk}^2 & s_{xkn} \\ s_{xn1} & s_{xni} & s_{xnk} & s_{xn}^2 \end{bmatrix} \quad (2)$$

Vector of measured values

$$\begin{bmatrix} m_1 \\ m_2 \\ m_3 \end{bmatrix} = \begin{bmatrix} 500 \\ 245 \\ 250 \end{bmatrix} \quad (3)$$

Restrictions

$$m_1 - m_2 - m_3 = 0 \quad (4)$$

Vector of restrictions

$$f(\bar{x}) = (m_1 - m_2 - m_3) = 0 \quad (5)$$

$f(\bar{x}) = f(x) + \frac{\partial f}{\partial x} v$  where  $f(x)$  – Vector of contradictions,  $v$  - Corrective vector applied to the present example

$$\frac{\partial f}{\partial x} = (1 \quad -1 \quad -1) \text{ and } f(x) = m_1 - m_2 - m_3 = 5 \quad (6)$$

and  $S_x$

$$S_x = \begin{bmatrix} 162,69 & 0 & 0 \\ 0 & 39,06 & 0 \\ 0 & 0 & 40,67 \end{bmatrix} \quad (7)$$

The minimization problem

$$v \cdot S_x^{-1} \cdot v - 2\lambda \cdot f(\bar{x}) = \xi_0 \rightarrow \text{Min} \quad (8)$$

yields, after a few adjustments and the linearization of  $f(\bar{x}) = f(x) + \frac{\partial f}{\partial x} v$  (9),

the corrective vector

$$v = - \left( \frac{\partial f}{\partial x} S_x \right)^T \cdot \left( \frac{\partial f}{\partial x} S_x \cdot \left( \frac{\partial f}{\partial x} \right)^T \right)^{-1} \cdot f(x) \quad (10)$$

With the values specified above it can be calculated that

$$\left( \frac{\partial f}{\partial x} S_x \right)^T \cdot \left( \frac{\partial f}{\partial x} S_x \cdot \left( \frac{\partial f}{\partial x} \right)^T \right)^{-1} = \begin{bmatrix} 0,673 \\ -0,161 \\ -0,168 \end{bmatrix} \quad (11) \text{ and}$$

**Figure 3:** Example

$$v = - \begin{bmatrix} 0,673 \\ -0,161 \\ -0,168 \end{bmatrix} [5] = \begin{bmatrix} -3,36 \\ 0,81 \\ 0,84 \end{bmatrix} \quad (12)$$

As a result, the restriction fulfilling values yield

$$\bar{m} = \begin{bmatrix} \bar{m}_1 \\ \bar{m}_2 \\ \bar{m}_3 \end{bmatrix} = m + v = \begin{bmatrix} 500 \\ 245 \\ 250 \end{bmatrix} + \begin{bmatrix} -3,36 \\ 0,81 \\ 0,84 \end{bmatrix} = \begin{bmatrix} 496,64 \\ 245,81 \\ 250,84 \end{bmatrix} \quad (13)$$

The covariance matrix of corrections can be calculated as follows:

$$S_v = - \left( \frac{\partial f}{\partial x} S_x \right)^T \cdot \left( \frac{\partial f}{\partial x} S_x \cdot \left( \frac{\partial f}{\partial x} \right)^T \right)^{-1} \cdot \left( \frac{\partial f}{\partial x} S_x \right) \quad (14)$$

Implemented into the example it yields

$$S_v = \begin{bmatrix} 109,49 & -26,24 & -27,3 \\ -26,2 & 6,28 & 6,54 \\ -27,33 & 6,55 & 6,83 \end{bmatrix} \quad (15)$$

and the corrected covariance matrix

$$S_{\bar{x}} = S_x - S_v = \begin{bmatrix} 162,69 & 0 & 0 \\ 0 & 39,06 & 0 \\ 0 & 0 & 40,67 \end{bmatrix} - \begin{bmatrix} 109,49 & -26,24 & -27,3 \\ -26,2 & 6,28 & 6,54 \\ -27,33 & 6,55 & 6,83 \end{bmatrix} =$$

$$S_{\bar{x}} = \begin{bmatrix} 53,2 & 26,24 & 27,3 \\ 26,2 & 32,78 & -6,54 \\ 27,3 & -6,55 & 33,84 \end{bmatrix} \quad (16)$$

With the corrected covariance matrix and equation (1), the new corrected confidence intervals can be calculated.  $v_{xi} = \sqrt{S_{xi}^2} \cdot t$  with  $t = 1,96$  implying a 95% confidence interval (17) So you get the vector  $m_{NEW}$  without contradiction

$$m_{NEW} = \begin{bmatrix} 496,64 \pm 14,3 \text{ t/h} \\ 245,81 \pm 11,2 \text{ t/h} \\ 250,84 \pm 11,4 \text{ t/h} \end{bmatrix} \quad (18)$$

**Figure 4:** Example-continue

```

NUMBER OF EQUATIONS :                4
NUMBER OF UNMEASURED VARIABLES :     3
NUMBER OF MEASURED VARIABLES :       3
NUMBER OF VARIABLES CONSIDERED CONSTANT : 0
OBVIOUS NUMBER OF REDUNDANCIES :     1
TOTAL NUMBER OF REDUNDANCIES :       1
NUMBER OF TRIVIAL REDUNDANCIES :     0

```

Convergence achieved

```

* OBJECTIVE FUNCTION                = 10.9366
CHI-SQUARE                          = 3.84000
SUM OF SQUARE RESIDUES              = 0.202146E-27
NUMBER OF BOUNDS ACTIVATED BY SOLVER = 0
NUMBER OF VARIABLES CLOSE TO BOUNDS = 0
NUMBER OF ELIMINATED TAGS          = 0
NUMBER OF FLAGGED TAGS              = 0

```

PENAL. : Penalty according to VDI-2048 =  
( Correction / SQRT( Max ( Variance(correction) , Variance(measure) / 10. ) ) \*\* 2

TAG NAME	MEA.VAL.	MEA.ACC.	REC.VAL.	REC.ACC.	PENALTY	P.U.
* STREAM1_M	550.00	5.00 %	510.86	2.89 %	10.94	t/h
* STREAM2_M	245.00	5.00 %	252.77	4.49 %	10.94	t/h
* STREAM3_M	250.00	5.00 %	258.09	4.47 %	10.94	t/h

Figure 5: Example with gross error

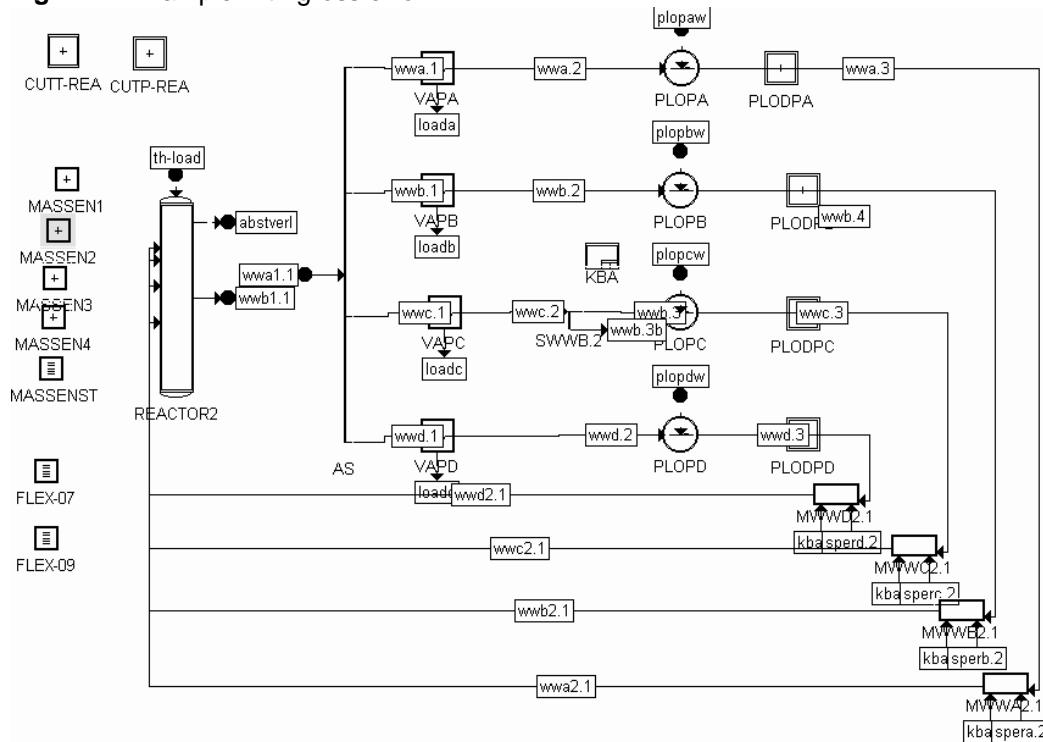
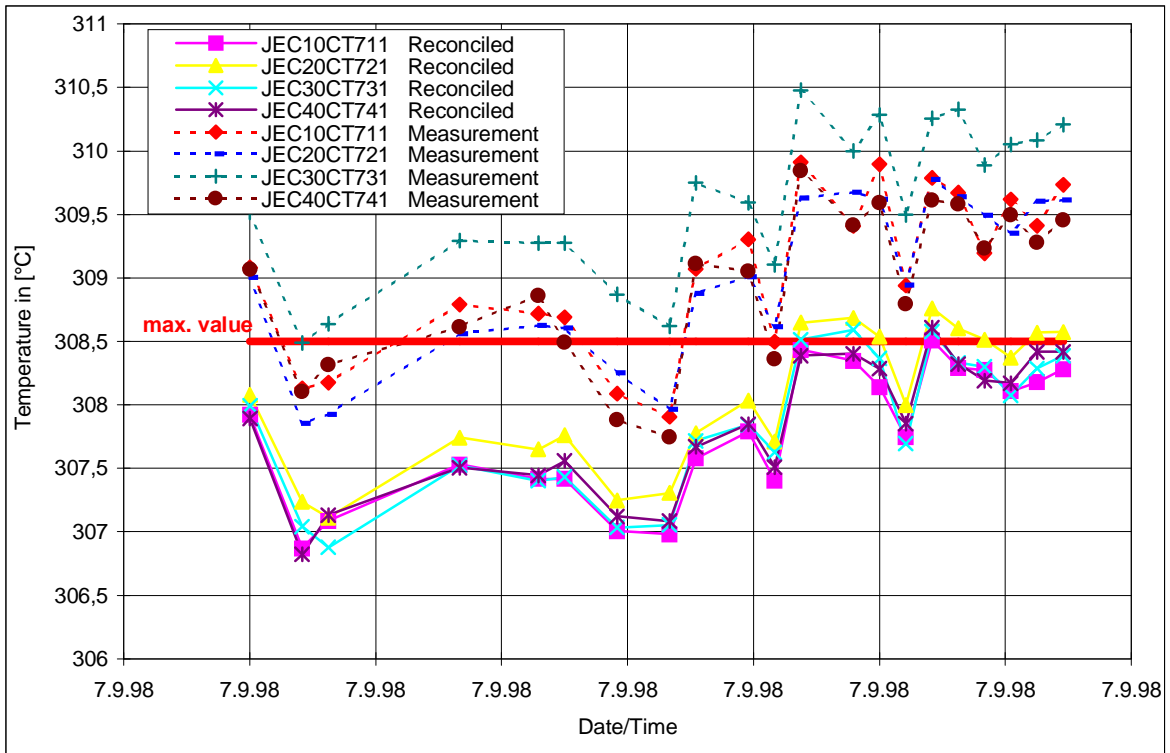
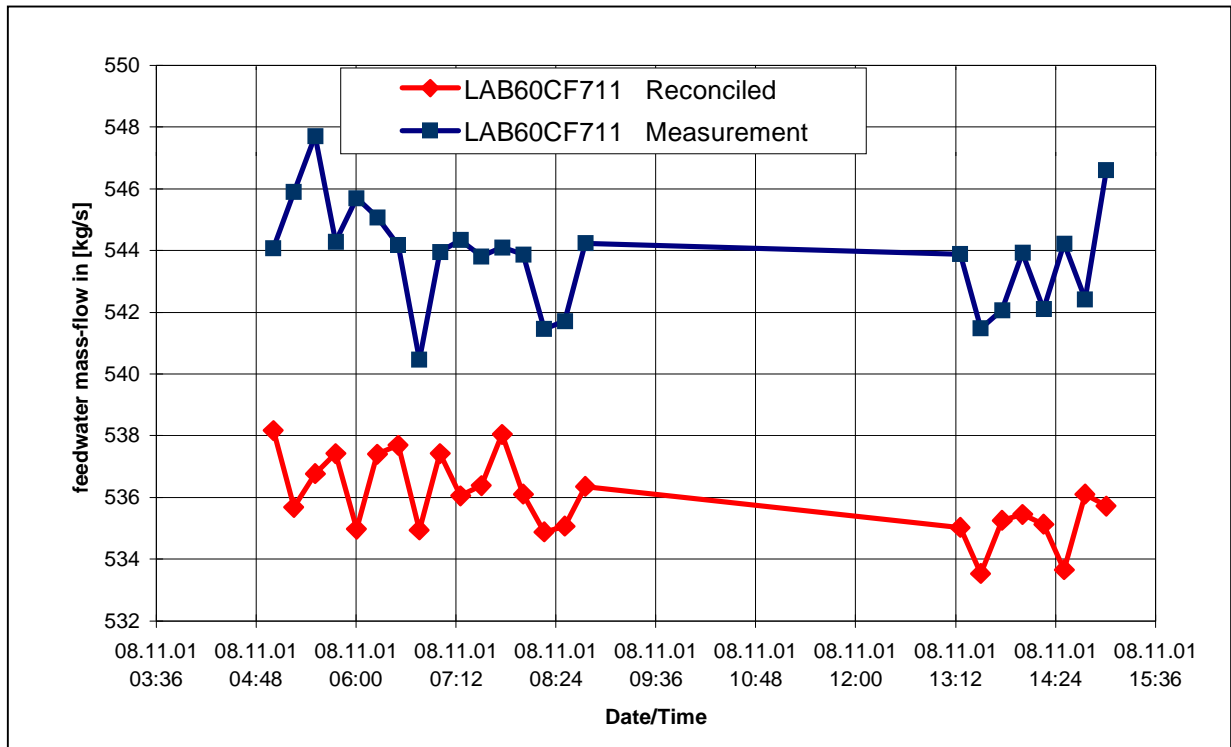


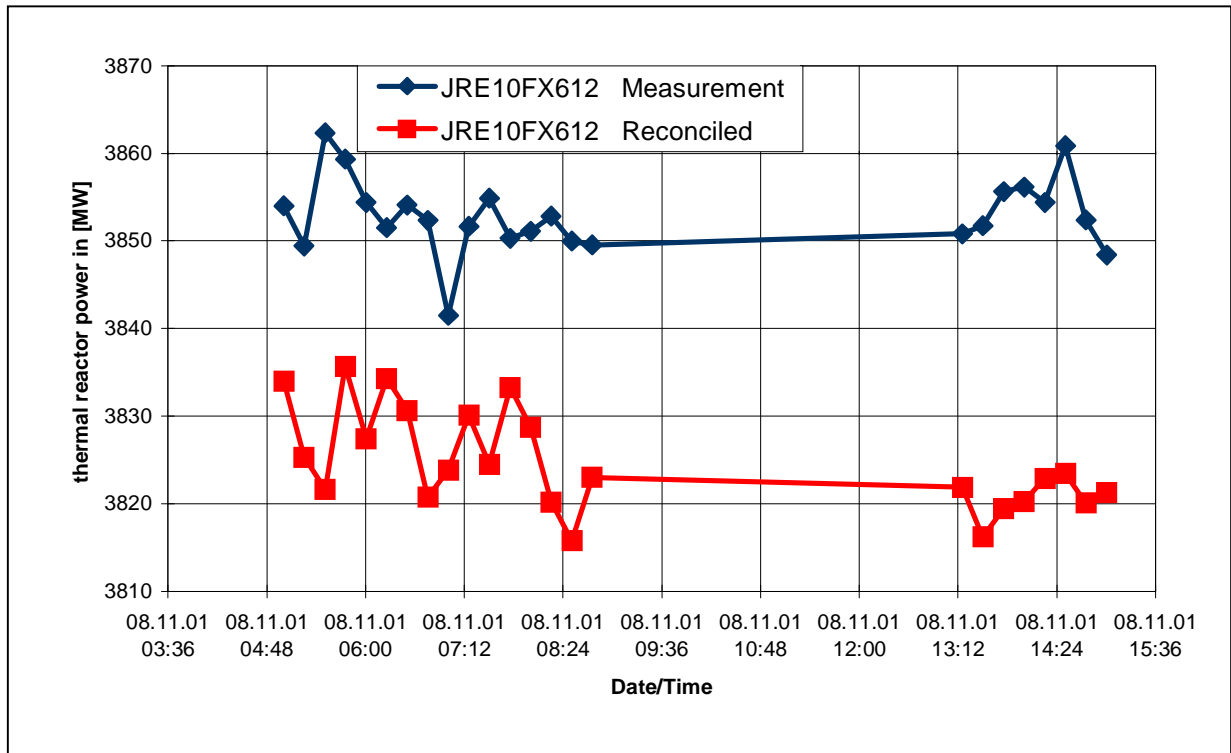
Figure 6: Primary circuit of a nuclear power plant – 4 LOOP PWR



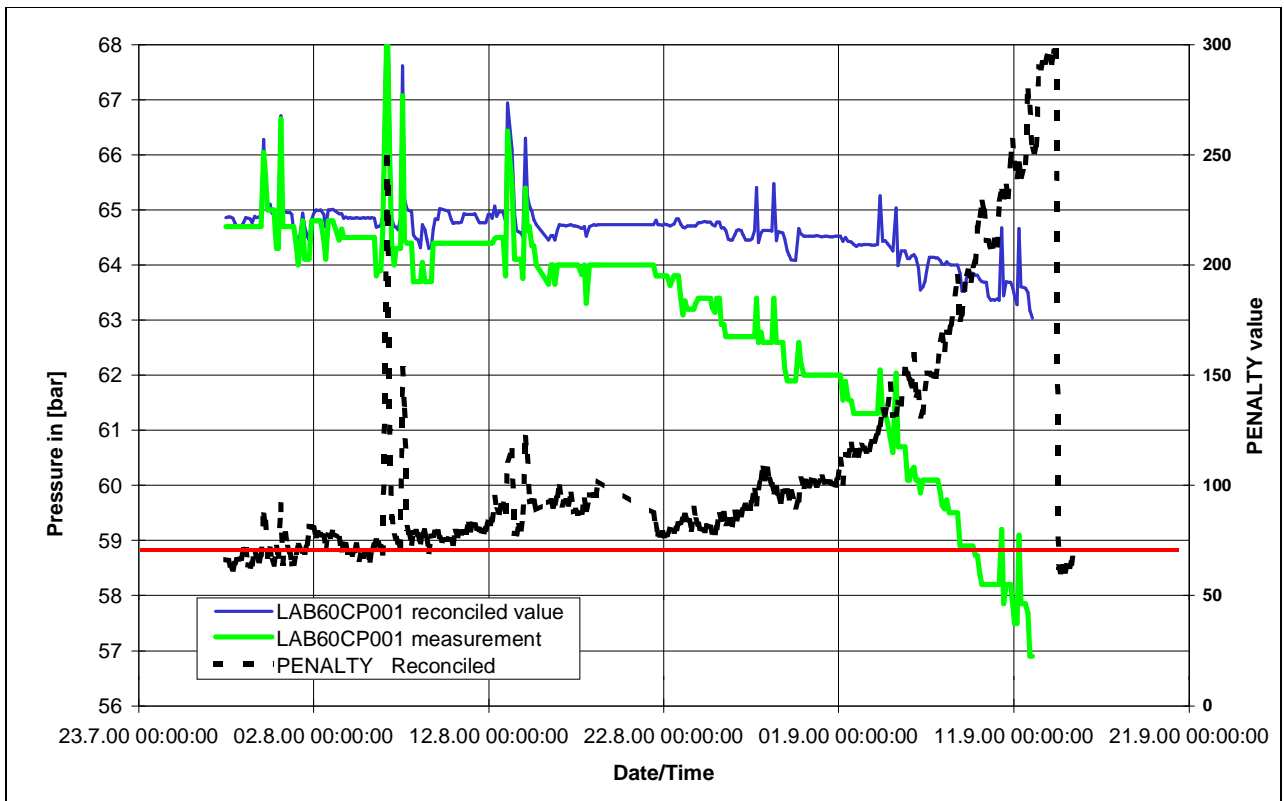
**Figure 7:** Graph of the mean coolant temperature – 4 LOOP PWR



**Figure 8:** Feed water mass flow LAB60CF711-4 LOOP PWR



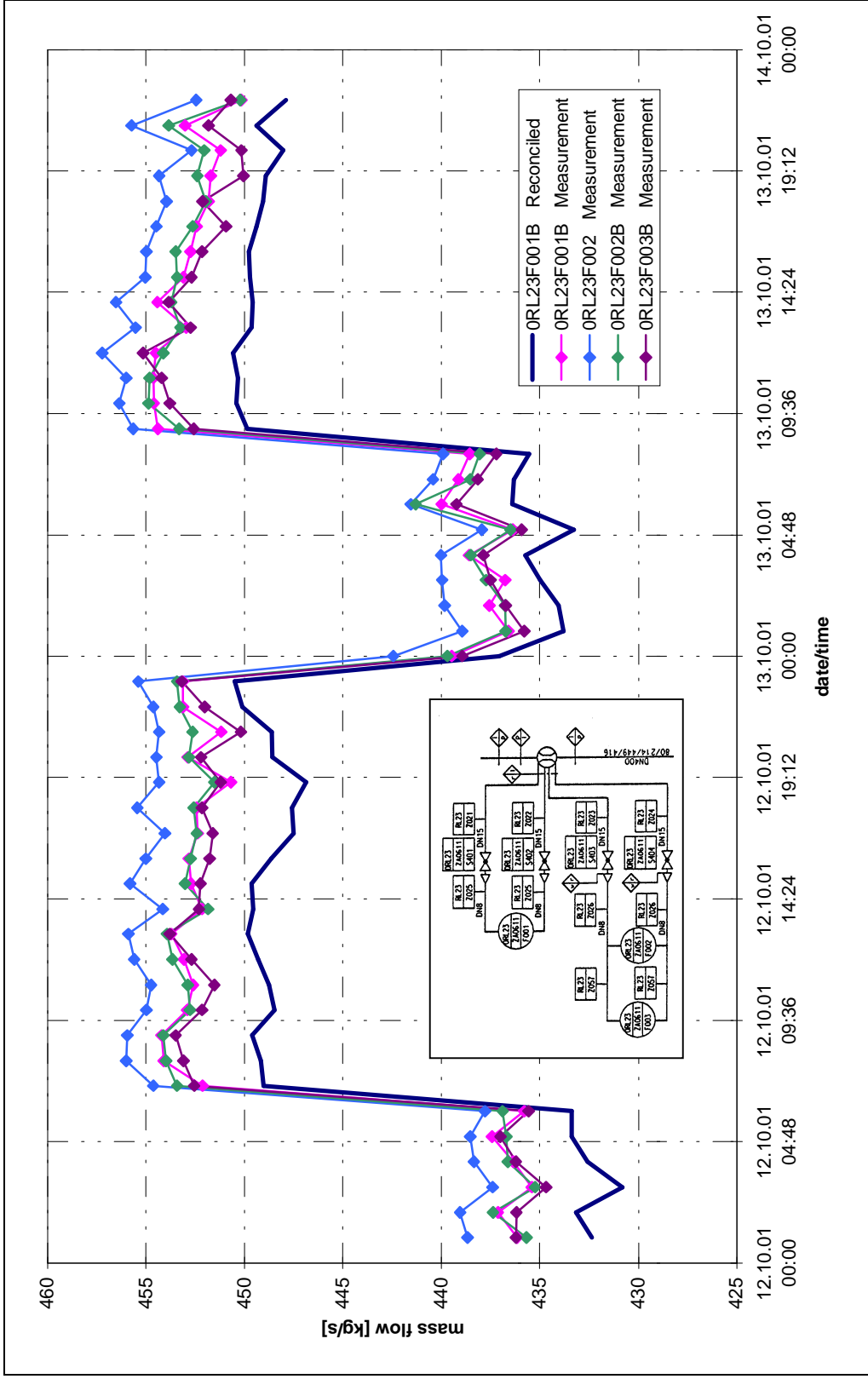
**Figure 9:** Measured and reconciled thermal reactor power -4 LOOP PWR



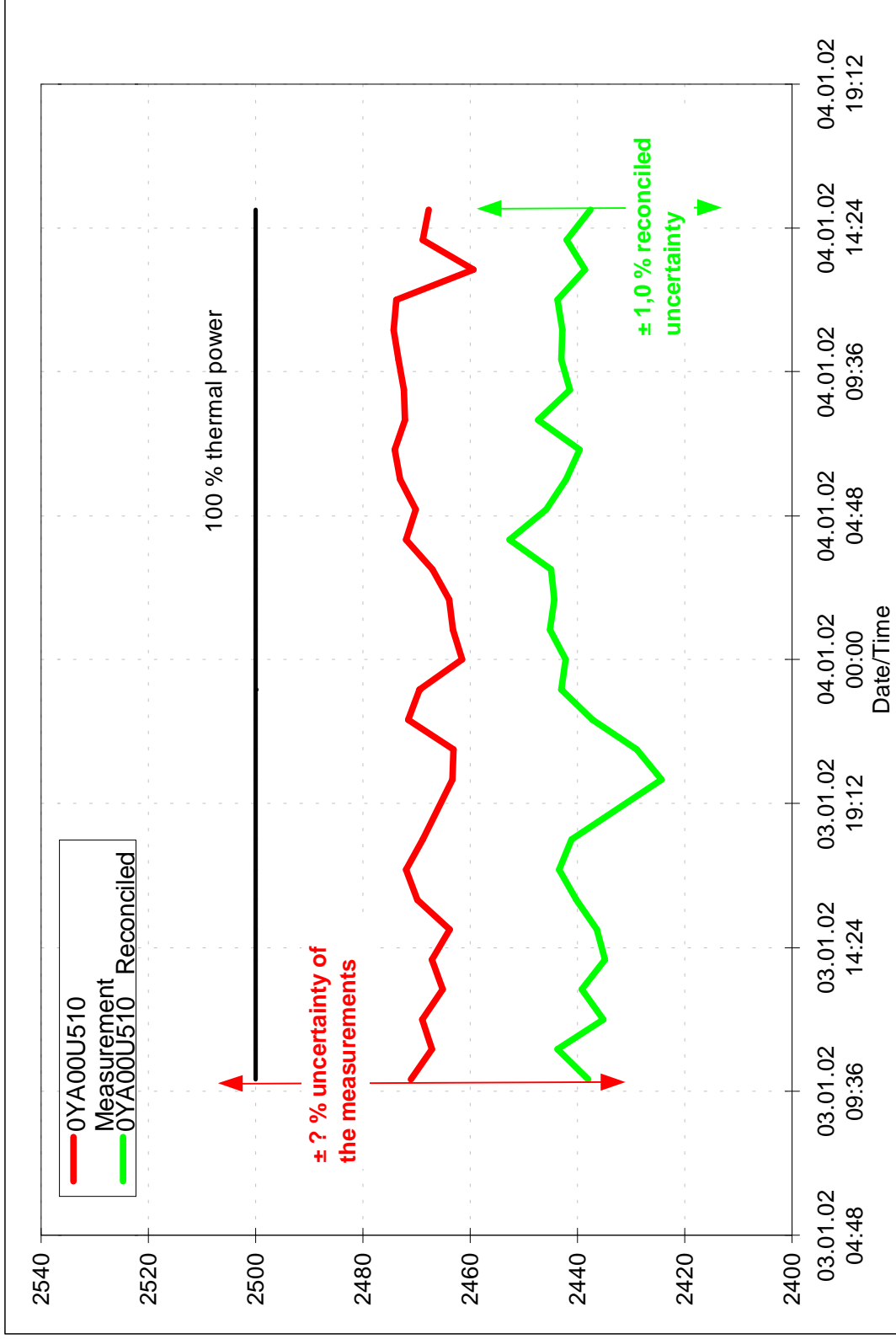
**Figure 10:** Drifting measuring point-4 LOOP PWR



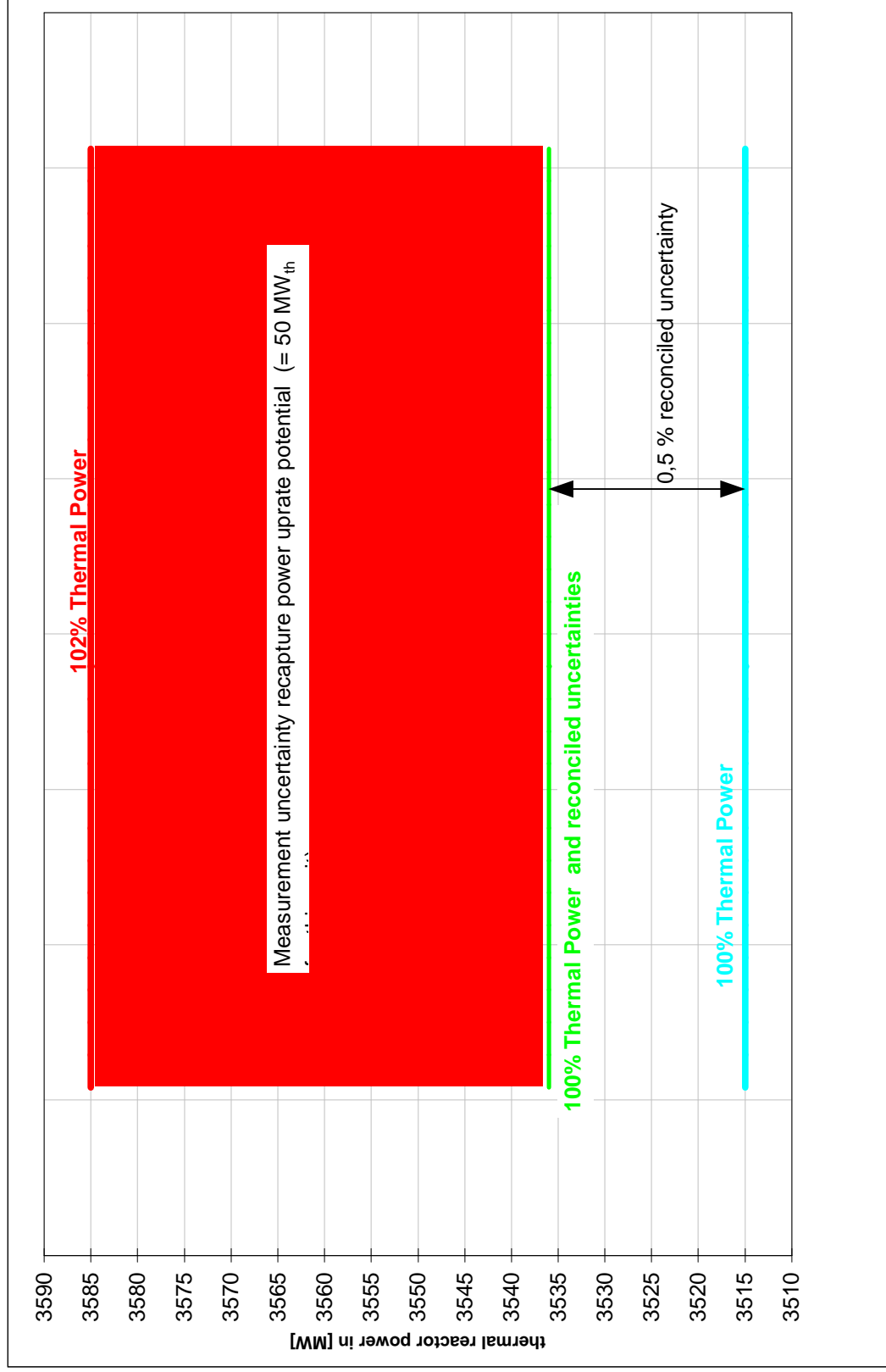




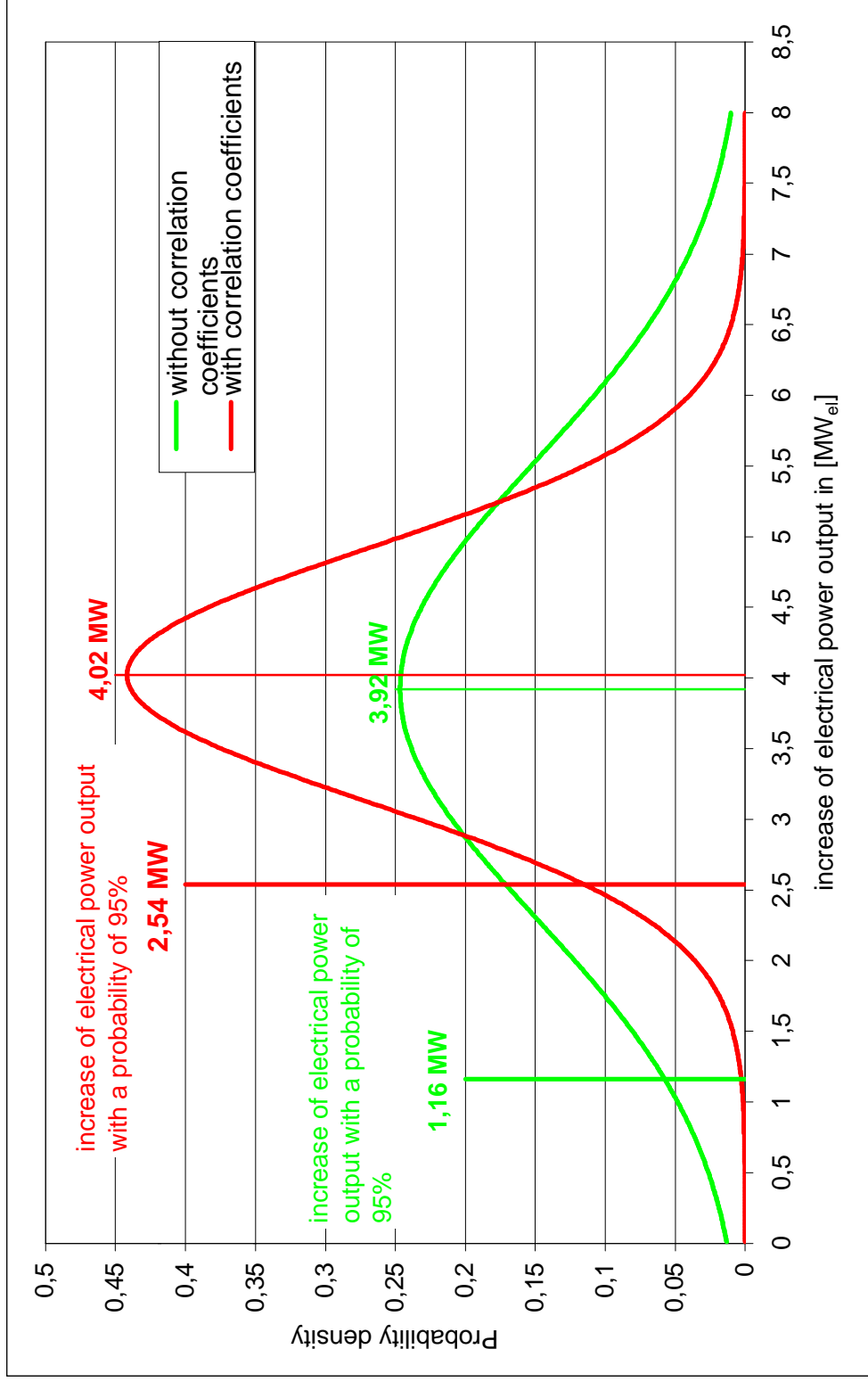
**Fig. 13: Feed water mass flow -3 LOOP PWR**



**Fig. 14:** Measured and reconciled thermal reactor power -3 LOOP PWR



**Figure 15:** Measurement uncertainty recapture power uprate potential -BWR



**Figure 16:** Evaluation of a maintenance activity (Compressor cleaning in a CCGT) with and without correlation coefficients